

## A7V #505 "Baden"

German WWI Heavy Tank  
1/72 Scale

copyright 2006 Clifton W. McCullough

A7V #505 "Baden" had one of the 5 Roechling 31-bolt hulls with a buck-type cannon mount.

The model shows it as it was until early April, 1918. "Baden" got stuck in barbed wire during St. Quentin on March 21, 1918. At that time "Baden" was commanded by Lt. Voss, in Abteilung 1 commanded by Hauptmann Greiff. Tanks were not numbered within the Abteilung at that time.

Afterwards, #505 "Baden" received its sole cannon mount and served in Abt. 3 at Villers-Bretonneaux and later. Camouflage and markings were slightly revised before Villers-Bretonneaux. The name was changed to "Baden I"

#505 served through the remainder of the war and was taken by the French at Wiesbaden-Erbenheim in December, 1918.  
#505 "Baden" finished the war

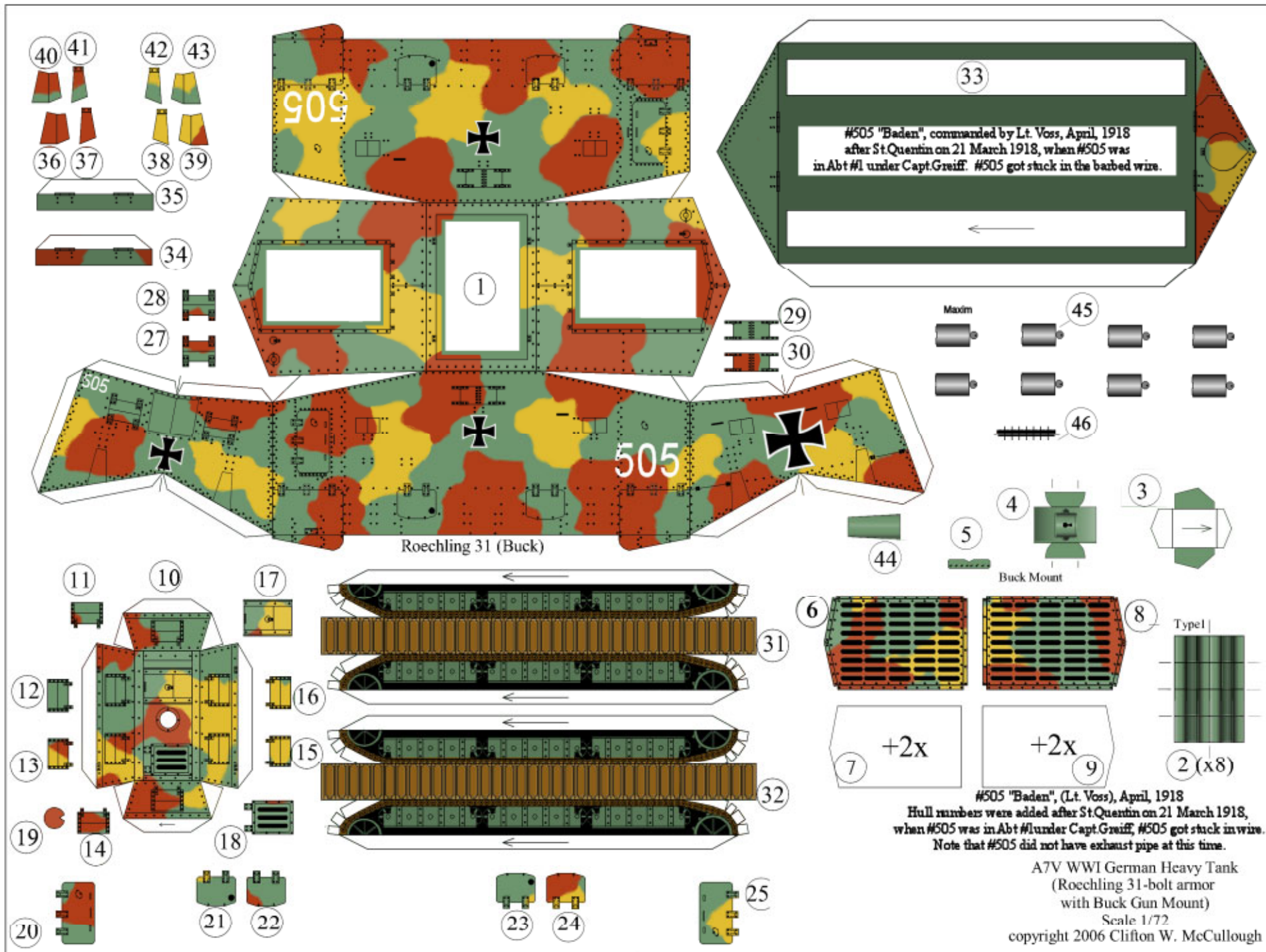

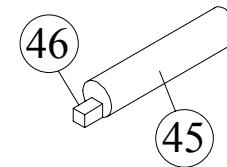
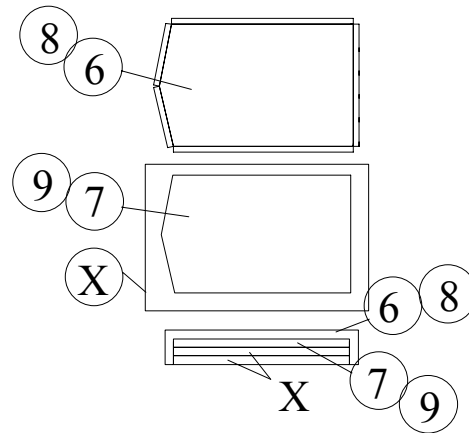
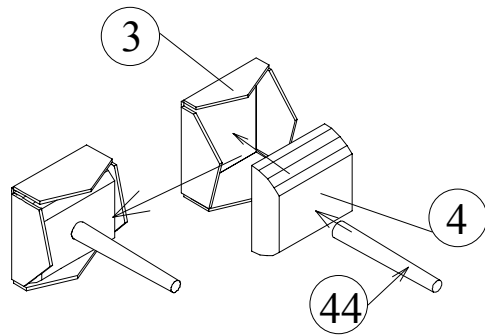
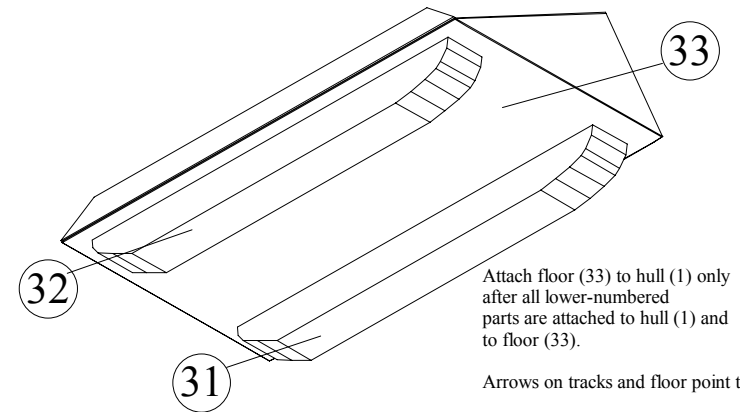
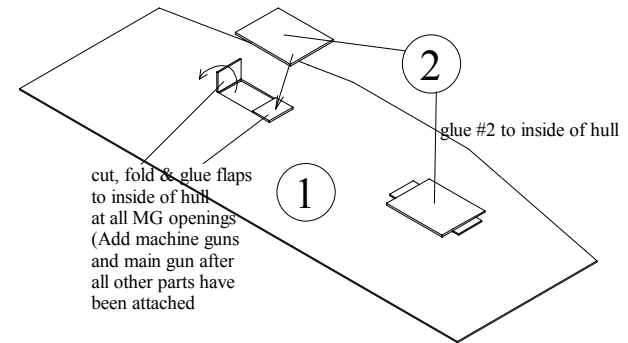
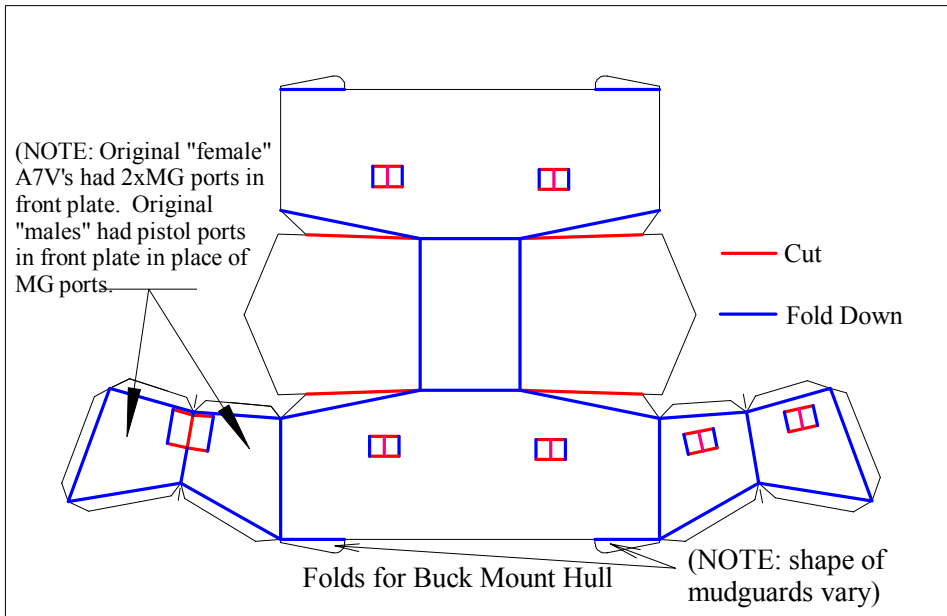

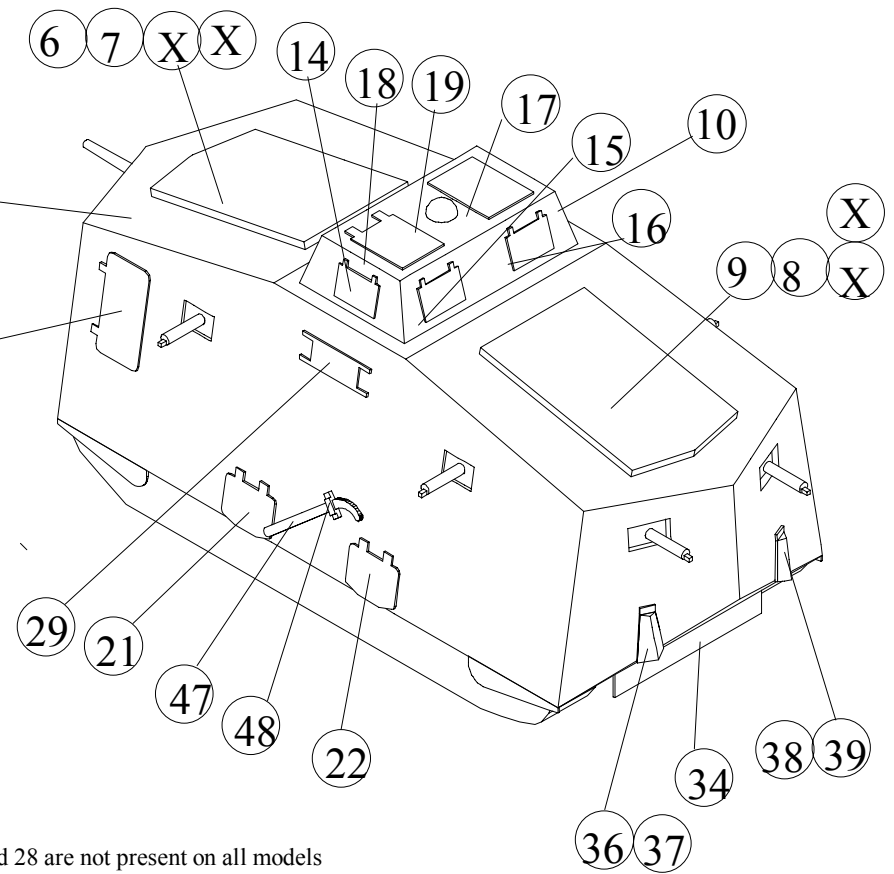
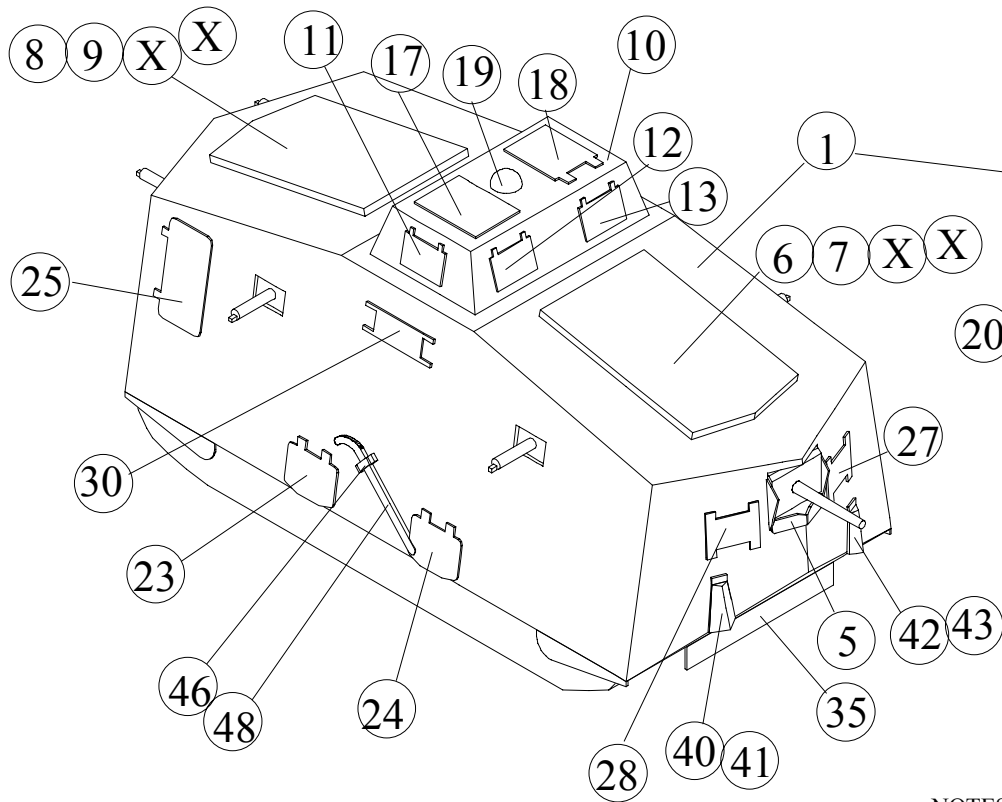

NOTES:

- Parts 27 and 28 are not present on all models
- #501 "Gretchen" as female has 2 MG's in front plate instead of parts 27 and 28

